



## Z1320-C Trouble-shooting Guide

PROBLEM	CAUSE	SOLUTION
Hydrant will not operate when turned on	Water supply is shut off	Turn on water supply
Cannot turn the hydrant on with key	Hydrant hasn't been used for a long time — "O" ring has adhered to operating screw and head	Follow steps 1-2, 5 and 9-10 of the Service Guide
Water running continuously from orifice in operating screw. NOTE: When first turning hydrant on, water may spit for a few seconds until ball seats on "O" ring	Debris between ball and "O" ring (in operating screw)	Follow steps 1-2, 6 and 9-10 of the Service Guide
	Ball "O" ring not seated properly (in operating screw)	Follow step 1-2, 6 and 9-10 of the Service Guide
Water sprays from holes around nozzle when hydrant is on	Equa-Balance® seal is damaged	Follow steps 1-3 and 9-10 of the Service Guide
Hydrant will not self-drain when it is shut off (hose and nozzle are attached)	Screw nozzle is closed	Open screw nozzle so hose will drain some, relieving pressure
	Gun nozzle is closed	Squeeze gun nozzle trigger so hose will drain some, relieving pressure
Water does not shut completely off when hydrant is turned off	Debris between seat and washer	Follow steps 1-2, 4 and 8-10 of the Service Guide. Clean by turning water supply on and flush hydrant
	Washer is worn out	Follow steps 1-2, 4 and 7-10 of the Service Guide
	Wire draw in seat	Replace seat
Hydrant exhibits low flow	Water supply to hydrant is restricted	Check water supply to ensure that all upstream valves are fully open

## Z1320-C Ecolotrol Wall Hydrant

**Encased • Automatic Draining  
Non-Freeze • Anti-Siphon**

### Maintenance and Service Instructions

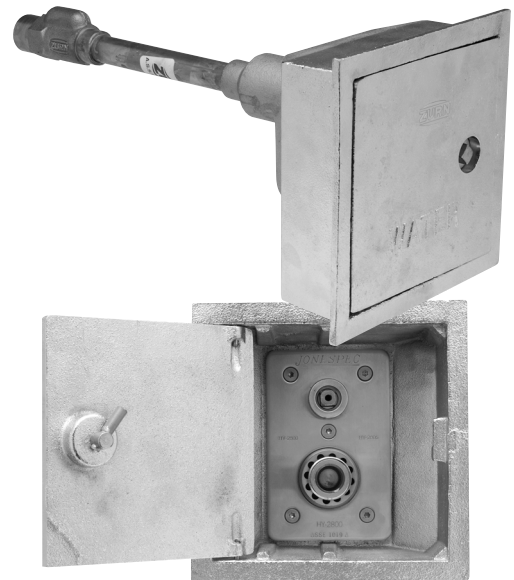

The Zurn Ecolotrol Hydrant has been engineered to provide reliable performance year after year. However, if servicing is required, it is recommended that you consult the trouble-shooting guide at the left. The trouble-shooting guide was developed to reduce maintenance time by providing the user with appropriate service instructions.

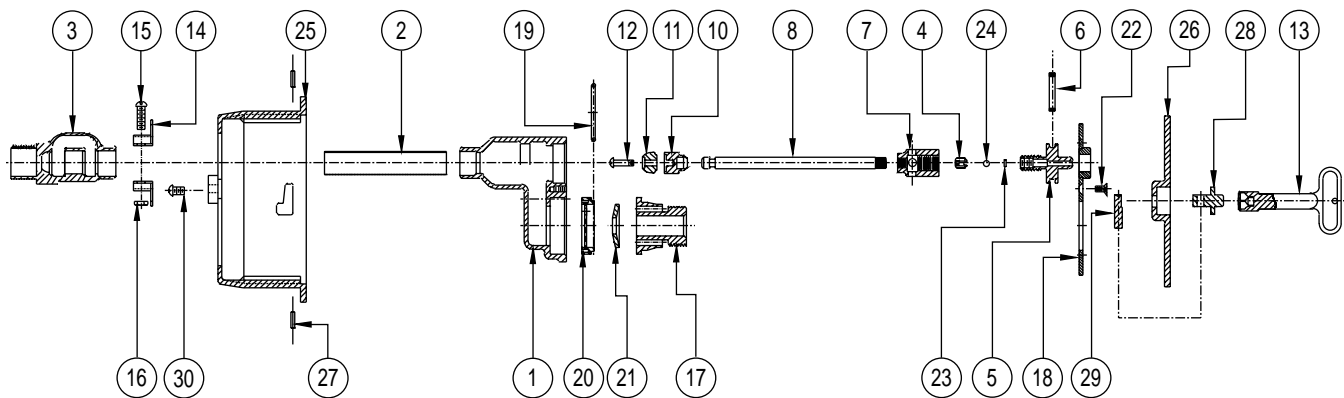

**Step 1: Shutting Off the Water Supply to the Hydrant**

Locate the supply shut-off valve and rotate until water supply is off.

**Step 2: Removing the Faceplate and Adjacent Components**

Using 1/8 Allen wrench, remove the five faceplate screws (22) from head (1) by turning counter clockwise. Remove the faceplate (18), and nozzle (17).  
If the Equa-Balance® seal was not the reason for service - skip to step 4.

**Step 3: Replacing the Equa-Balance® Seal**

Remove the current Equa-Balance® seal (21). Check seal for damage (punctures, rips, etc.). Replace damaged seal with a new seal (23) observing proper orientation (EQUA-BALANCE® SEAL SHOULD CUP INWARD IN ITS REPLACED STATE.)

**Step 4: Removing the Internal Operating Assembly**

The internal operating assembly (4-8,10-12 and 23-24) can be removed by gripping the square end of the operating screw (5) with a pair of pliers and pulling straight out.  
If the operating screw "O" ring was not the reason for service - skip to step 6.

**Step 5: Replacing the Operating Screw "O" Ring**

Remove the operating screw (5) from operating coupling (7) by turning clockwise and slip the old "O" ring (6) off, and replace with new "O" ring (6). Reinstall operating screw (5) into operating coupling (7) by turning counter clockwise. (NOTE: Lubricate the operating screw (5) threads and the "O" Ring (6) with Lubriplate FGL-2 if needed.)

If the operating screw assembly was not the reason for service - skip to step 7.

**Step 6: Checking Operating Screw Assembly**

Remove the operating screw (5) from the operating coupling (7) by turning clockwise, and using 5/32 Allen wrench, remove set screw (4) by turning counter clockwise, remove stainless steel ball (24) and check orientation of "O" ring (23). If not seated properly, reseal, replace the ball (24) and replace set screw (4) using Allen wrench and turning clockwise until flush with operating screw (5) or until tight and flush with operating screw (5). (NOTE: Lubricate and reinstall as in step 5.)

If the hydrant shutoff washer was not the reason for service - skip to step 8.

**Step 7: Replacing the Hydrant Shutoff Washer**

Remove #10 - 24 NC x 3/8 screw (12) using a flat screwdriver and turning screw (12) counter clockwise, remove washer (11) and replace with new washer (11) and new screw (12) turning screw clockwise until tight.

**Step 8: Replacing the Internal Operating Assembly**

There is a flat or a V-notched boss inside of the hydrant head (1) that keeps the operating coupling (7) from rotating when hydrant is turned on and off. With operating screw (5) turned counter clockwise into operating coupling (7) until it stops, and making sure that a flat side or corner of operating coupling (7) lines up with appropriate boss, reinsert the internal operating assembly into the hydrant.

**Step 9: Replacing the Faceplate**

Insert nozzle (17) into place and fasten the faceplate (18) to head (1) using the 1/8 Allen wrench and the five faceplate screws (22). Rotate the screws clockwise until screws are snugged tight. (By hand only!)

**Step 10: Turning On the Water Supply**

Locate the water supply shut-off valve and rotate until water supply is on.



**ZURN PLUMBING PRODUCTS GROUP**  
1801 PITTSBURGH AVENUE  
ERIE, PA 16502  
PHONE: 814/455-0921  
FAX: 814/875-1402  
WEBSITE: www.zurn.com

Dimensional Data (inches and [ mm ]) are Subject to Manufacturing Tolerances and Change Without Notice

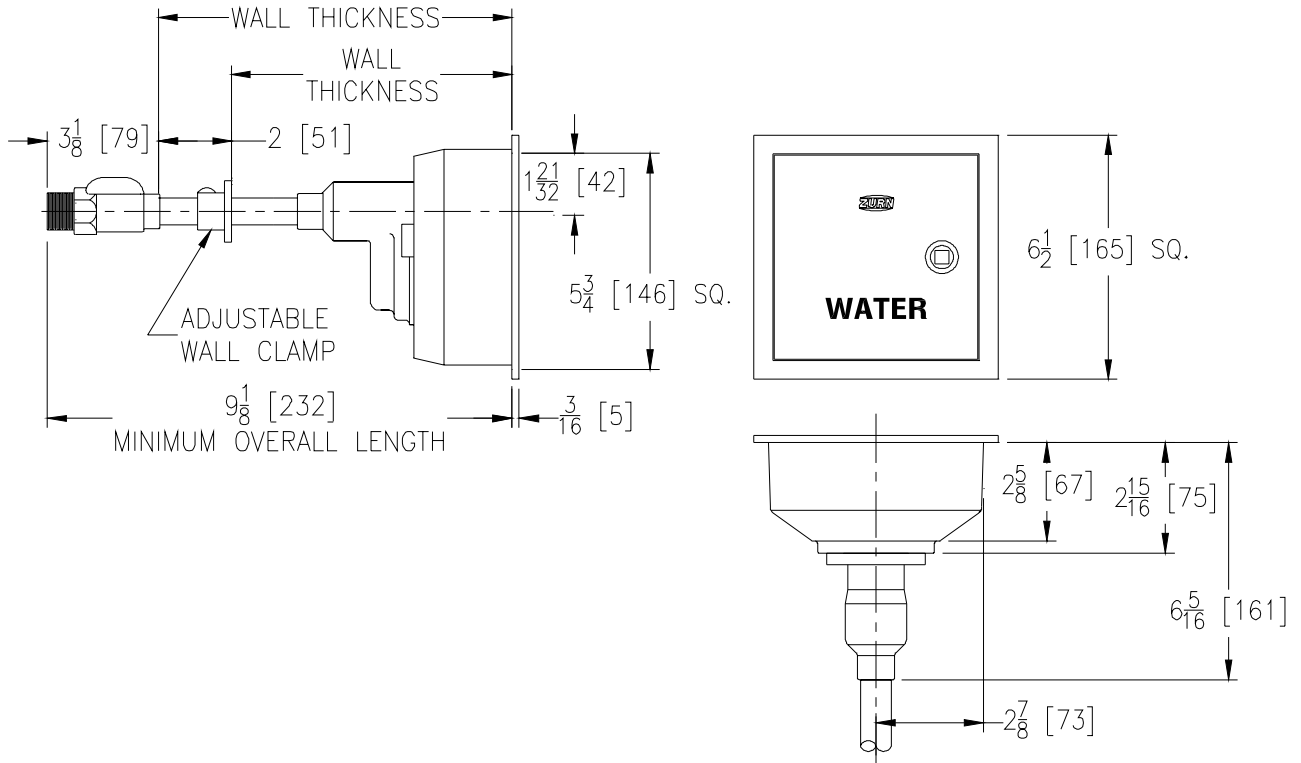

Wall Thickness In Inches	Approx. Wt. Lbs. [kg]
6-8 [152-203]	5 [2]
10-12-14-16 [254-305-356-406]	6 [3]
18-20-22-24 [457-508-559-610]	8 [4]

**ENGINEERING SPECIFICATION:** Z1320-C Encased Ecolotrol, anti-siphon, automatic draining, non-freeze wall hydrant complete with integral backflow preventer, copper casing, all bronze interior parts, non-turning operating rod with free-floating compression closure valve, and combination 3/4 [19] female solder and 3/4 [19] male pipe thread inlet connection standard. Regularly furnished with 3/4 [19] hose connection. Chrome-plated rough cast bronze box and hinged cover. Includes operating key.

**OPTIONS** (Check/specify appropriate options)

**SUFFIXES**

- \_\_\_ -34EL 3/4 [19] 90° Solder Inlet Elbow
- \_\_\_ -CL Cylinder Lock
- \_\_\_ -DU Combination 3/4 [19] Female Pipe Thread and 1 [25] Male Pipe Thread Connection
- \_\_\_ -NB Polished Nickel Bronze Finish
- \_\_\_ -PB Polished Bronze Finish
- \_\_\_ -RA2 12 [305] Wall Rod Assembly with Repair Kit (-RK)
- \_\_\_ -RA4 24 [610] Wall Rod Assembly with Repair Kit (-RK)
- \_\_\_ -RK Hydrant Parts Repair Kit
- \_\_\_ -SS Stainless Steel Finish
- \_\_\_ -WC Wall Clamp



1019-A



### Z1320-C and Z1321-C Ecolotrol Wall Hydrants 3/4" Hose Connection

The information provided is presented in two ways; chart and graph form. Once the hydrant and proper hose connection is established, all of the information can be obtained through the corresponding graph.

Choose a Static Inlet Pressure on the graph. Next draw a vertical line from this point until an intersection is made with the curve. Drawing a horizontal line from this intersection to the left axis will give the corresponding Running Inlet Pressure. The values listed above the curve indicate the Pressure Drop Across the Unit, and the values below the curve list the Flow Rate of the unit.

Note: All data was collected with the hydrant opened to its full capacity.

Example: At a static pressure of 47 psi, it can be found that the running inlet pressure of the unit is approximately 37.3 psi. The flow rate of the unit is between 8.5 and 9.2 gpm (approximately 9.0 gpm) and the pressure drop across the unit is between 28.6 and 36.5 psi (approximately 34.1 psi).

## Z1320-C and Z1321-C Ecolotrol Wall Hydrants

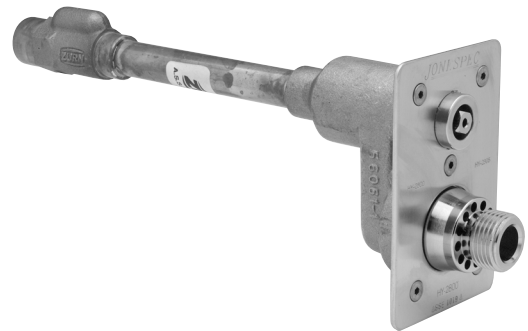
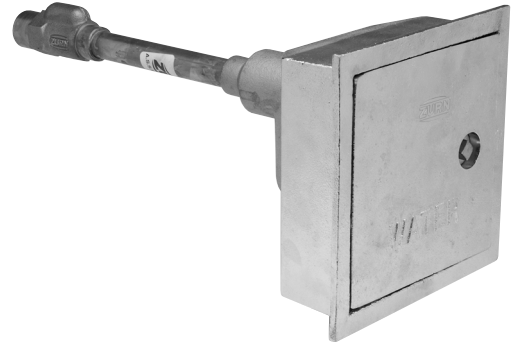

Z1320-C, Z1321-C Ecolotrol Wall Hydrant – 3/4" Hose Connection				
Static Pressure (psi)	Running Inlet Pressure (psi)	Running Outlet Pressure (psi)	Flow Rate (gpm)	Pressure Drop Across Unit (psi)
10	5.5	0.2	3.5	5.3
20	14.2	0.9	5.4	13.3
30	22.4	1.9	7.3	20.5
40	31.3	2.7	8.5	28.6
50	39.9	3.5	9.2	36.5
60	46.4	4.1	9.6	42.3
70	58.8	5.7	11.6	53.1
80	67.5	6.1	12.2	61.4
90	73.8	7.3	12.9	66.5

