



# KITCHEN SINK FAUCET Z871A4

TAG \_\_\_\_\_



### Engineering Specifications: Zurn AquaSpec® Z871A4

Polished chrome-plated 8" [203mm] brass deck faucet with a 3-1/2" [89mm] centerline rigid or swing gooseneck spout and quarter turn ceramic disc cartridges. Unit is furnished with a 2.2 GPM [8.3 L] pressure compensating aerator (complying with ANSI A112.18.1 Standard for flow), 4" [102mm] vandal-resistant color-coded metal wrist blade handles, mounting hardware and 1/2" NPSM coupling nuts for standard lavatory risers.

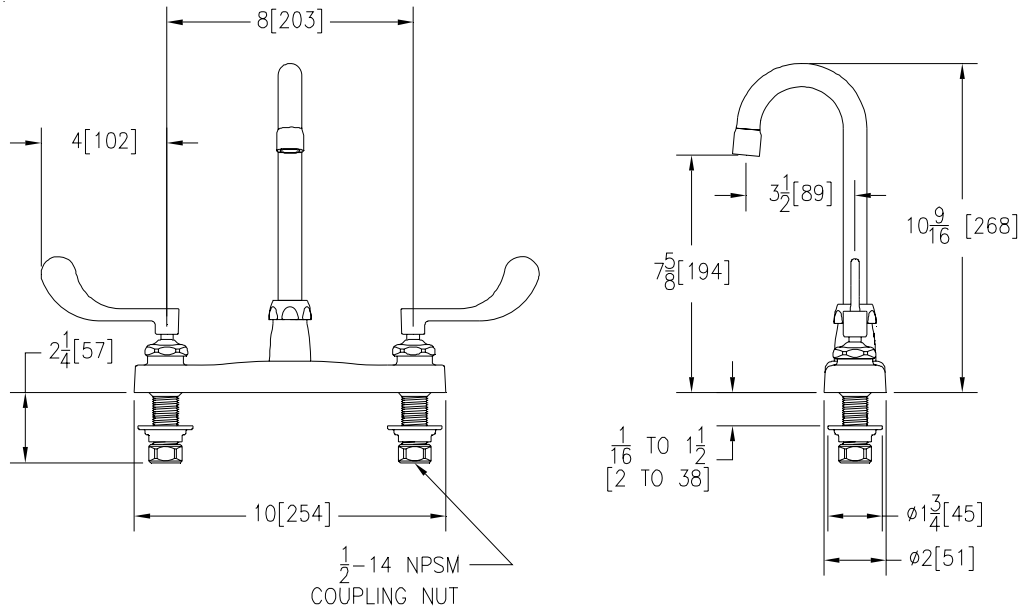

Note: All dimensions are for reference only. Do not use for pre-plumbing

### OPTIONAL ACCESSORIES

Suffix	Description
___-FC	2.0 GPM [7.6 L] Laminar Flow Control in Base of Spout
___-HCT	Hot/Cold Text Indexes
___-HS	Hose and Spray
___-PT	1-1/4" [32mm] Cast Brass P-Trap with a 7-1/2" [191mm] Long 17-Gauge Wall Bend
___-2F	2.2 GPM [8.3 L] Vandal-Resistant Pressure Compensating Female Aerator
___-3F	0.5 GPM [1.9 L] Vandal-Resistant Pressure Compensating Female Spray Outlet
___-4F	2.2 GPM [8.3 L] Vandal-Resistant Pressure Compensating Female Laminar Flow Outlet
___-5F	2.0 GPM [7.6 L] Female Spray Outlet
___-7F	1.0 GPM [3.8L] Pressure Compensating Female Spray Outlet
___-11F	Female Threaded Single Screen Outlet
___-16F	1.0 GPM [3.8L] Vandal-Resistant Pressure Compensating Female Spray Outlet
___-17F	1.5 GPM [5.7L] Vandal-Resistant Pressure Compensating Female Aerator
___-18F	1.5 GPM [5.7L] Vandal-Resistant Pressure Compensating Female Laminar Flow Outlet
___-19F	1.5 GPM [5.7 L] Anti-Microbial Pressure Compensating Female Laminar Flow Outlet
___-20F	1.0 GPM [3.8L] Vandal-Resistant Pressure Compensating Anti-Microbial Female Laminar Flow Outlet
___-21F	1.0 GPM [3.8L] Female Laminar Flow Outlet
___-22F	1.0 GPM [3.8L] Vandal-Resistant Female Laminar Flow Outlet
___-23F	1.5 GPM [5.7L] Pressure Compensating Female Aerator

ZURN INDUSTRIES, LLC ♦ COMMERCIAL BRASS OPERATION ♦ 2640 SOUTH WORK STREET ♦ FALCONER NY 14733

Phone: 1-800-997-3876 ♦ Fax: 1-919-775-3541 ♦ www.zurn.com

In Canada: ZURN INDUSTRIES LIMITED ♦ 3544 Nashua Drive ♦ Mississauga, Ontario L4V1L2 ♦ Phone: 905/405-8272 Fax: 905/405-1292