



Z1320

SPECIFICATION SHEET

ECOLOTROL CERAMIC DISC WALL HYDRANT Encased, Non-Freeze, Anti-Siphon, Automatic Draining

TAG _____

Dimensional Data (inches and [mm]) are Subject to Manufacturing Tolerances and Change Without Notice

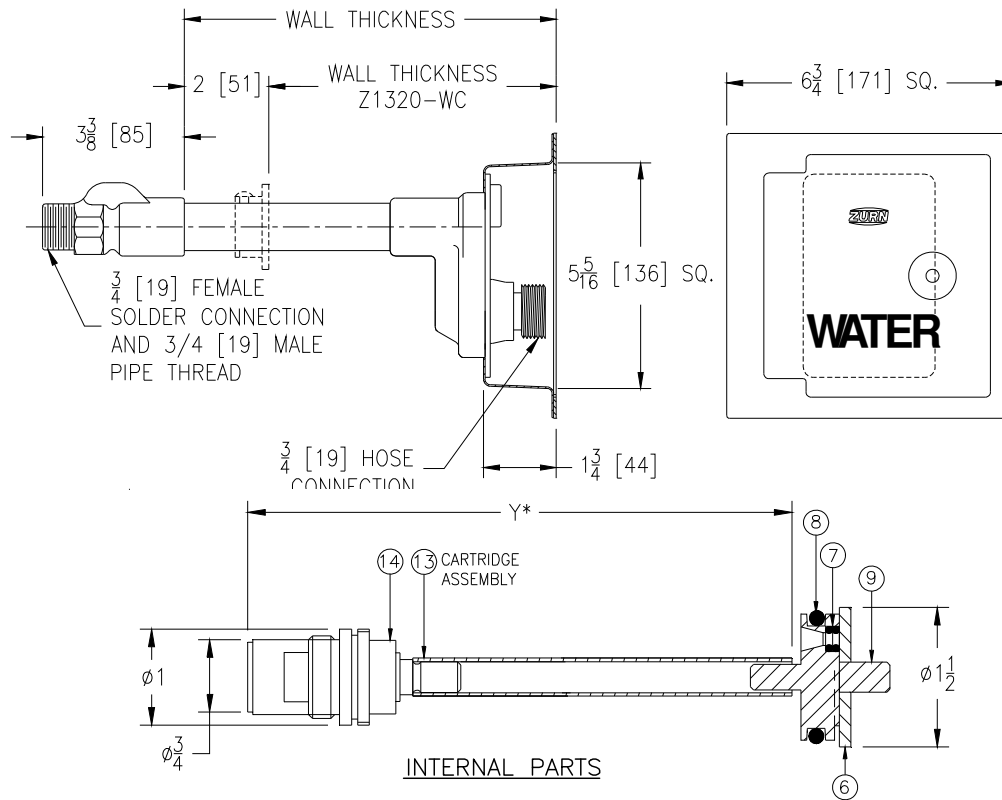

Wall Thickness Inches	Approx. Wt. Lbs. [kg]
6-8 [152-203]	5 [2]
10-12-14 [254-305-356]	6 [3]
16-18 [406-457]	7 [3]
20-22-24 [508-559-610]	8 [4]
26[660]	10[5]

ENGINEERING SPECIFICATION: ZURN Z1320 Encased Ecolotrol "anti-siphon" automatic draining wall hydrant for flush installation. Complete with integral backflow preventer, copper casing, all bronze interior parts with 1/2 turn ceramic disk cartridge and combination 3/4[19] female solder and 3/4[19] male pipe thread inlet. Stainless steel box and hinged cover with operating key lock and "WATER" stamped on cover. (All solder connections are lead free.)

OPTIONS (Check/specify appropriate options)

SUFFIXES

- ___ -CL Cylinder Lock
- ___ -NB Polished Nickel Bronze Face
- ___ -PB Polished Bronze Face
- ___ -RK Hydrant Parts Repair Kit
- ___ -RT12 Ceramic Cartridge Removal Tool (Up to 12 [305] Wall)
- ___ -RT24 Ceramic Cartridge Removal Tool (Up to 24 [610] Wall)
- ___ -RT36 Ceramic Cartridge Removal Tool (Up to 36 [915] Wall)
- ___ -WC Wall Clamp
- ___ -34EL 3/4 [19] IP 90° Solder Inlet Elbow
- ___ -34FIP 3/4 [19] IP Straight Female Inlet Adapter

PARTS LIST

Item	Name	Quan.
14	Cartridge	1
13	Operating Tube	1
9	Operating Coupling	1
8	'O' Ring	1
7	'O' Ring	2
6	Retaining Washer	1

*WHEN ORDERING REPLACEMENT CARTRIDGE ASSEMBLY SPECIFY Y DIM.

REV. F	DATE: 03/23/09	C.N. NO. 99837
DWG. NO. 58871	PRODUCT NO. Z1320	