



Z1332-EZ

SPECIFICATION SHEET

ECOLOTROL CERAMIC DISC WALL HYDRANT Encased, Anti-Siphon, Automatic Draining, Moderate Climate TAG _____

Dimensional Data (inches and [mm]) are Subject to Manufacturing Tolerances and Change Without Notice

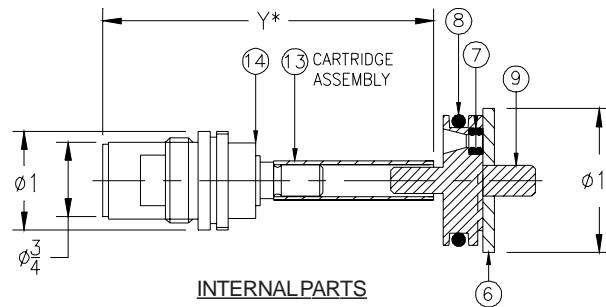
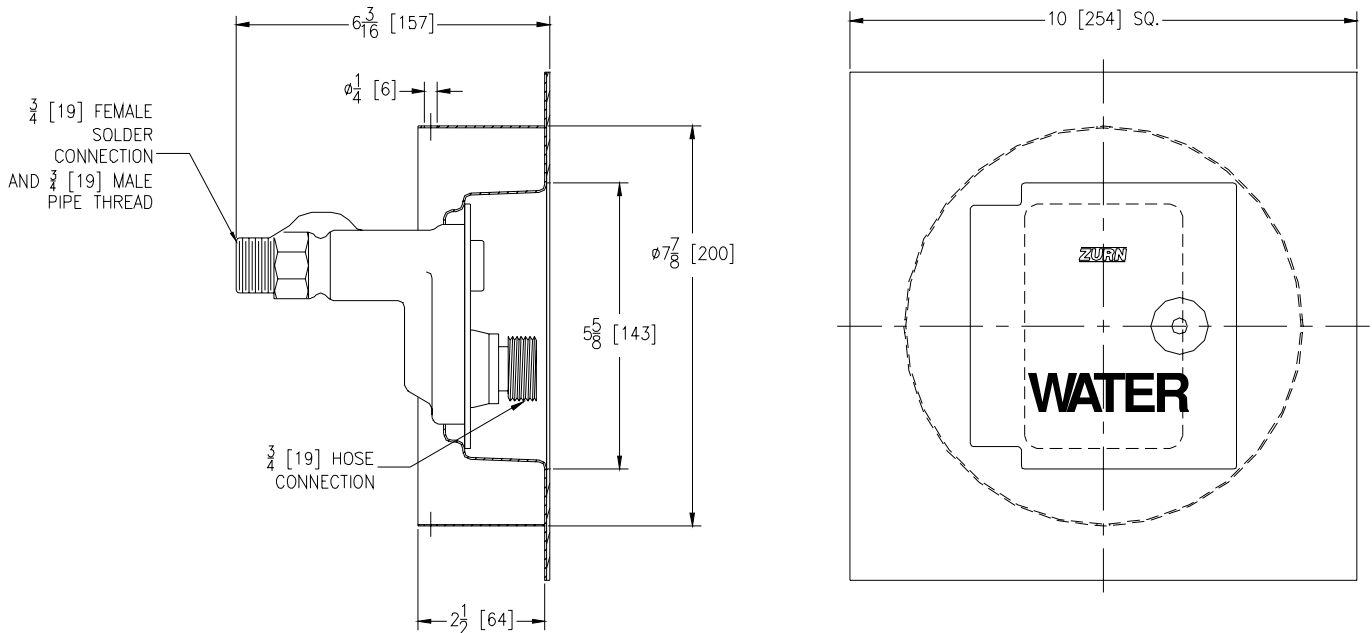

Wall Thickness In Inches	Approx. Wt. Lbs. [kg]
8 [203]	4 [2]

ENGINEERING SPECIFICATION: ZURN Z1332-EZ Encased Ecolotrol "anti-siphon" moderate climate/interior wall hydrant. For flush installation in 8 [203] dia. cored hole concrete wall. Complete with integral backflow preventer, all bronze interior parts with 1/2 turn ceramic disk cartridge and combination 3/4 [19] female solder and 3/4 [19] male pipe thread inlet. Stainless steel large flange box and hinged cover with operating key lock and "WATER" stamped on cover.

OPTIONS (Check/specify appropriate options)

SUFFIXES

- _____ -CL Cylinder Lock
- _____ -RK Hydrant Parts Repair Kit
- _____ -RT12 Ceramic Cartridge Removal Tool (Up to 12 [305] Wall)
- _____ -34EL 3/4 [19] 90° Solder Inlet Elbow
- _____ -34FIP 3/4 [19] IP Straight Female Inlet Adapter

PARTS LIST

Item	Name	Quan.
14	Cartridge	1
13	Operating Tube	1
9	Operating Coupling	1
8	O-Ring	1
7	O-Ring	2
6	Retaining Washer	1

PATENTED

PAT. NO. 7,395,834

REV. B	DATE: 7/2/08	C.N. NO. 98717
DWG. NO. 67500		PRODUCT NO. Z1332-EZ

* WHEN ORDERING REPLACEMENT CARTRIDGE ASSEMBLY PARTS SPECIFY 'Y' DIM.