

Engineering Specifications: Zurn AquaSpec® Z826X1

Polished chrome plated deck mounted pre-rinse faucet with an integral shank, quarter turn ceramic disc cartridges, a mixing yoke with 1/2" check stop inlets and 2-1/2"[64mm] vandal resistant color-coded metal lever handles. Unit is furnished with a 24"[610mm] riser, a 36" [914mm] stainless steel spring hose, a self-closing 1.24 GPM @ 60 psi (4.7 L/min. @ 400 kPa) pre-rinse hand held valve with an insulated 6"[152mm] handle, a stay open clip, a protective bumper spray head, a pipe support and a hose hook.

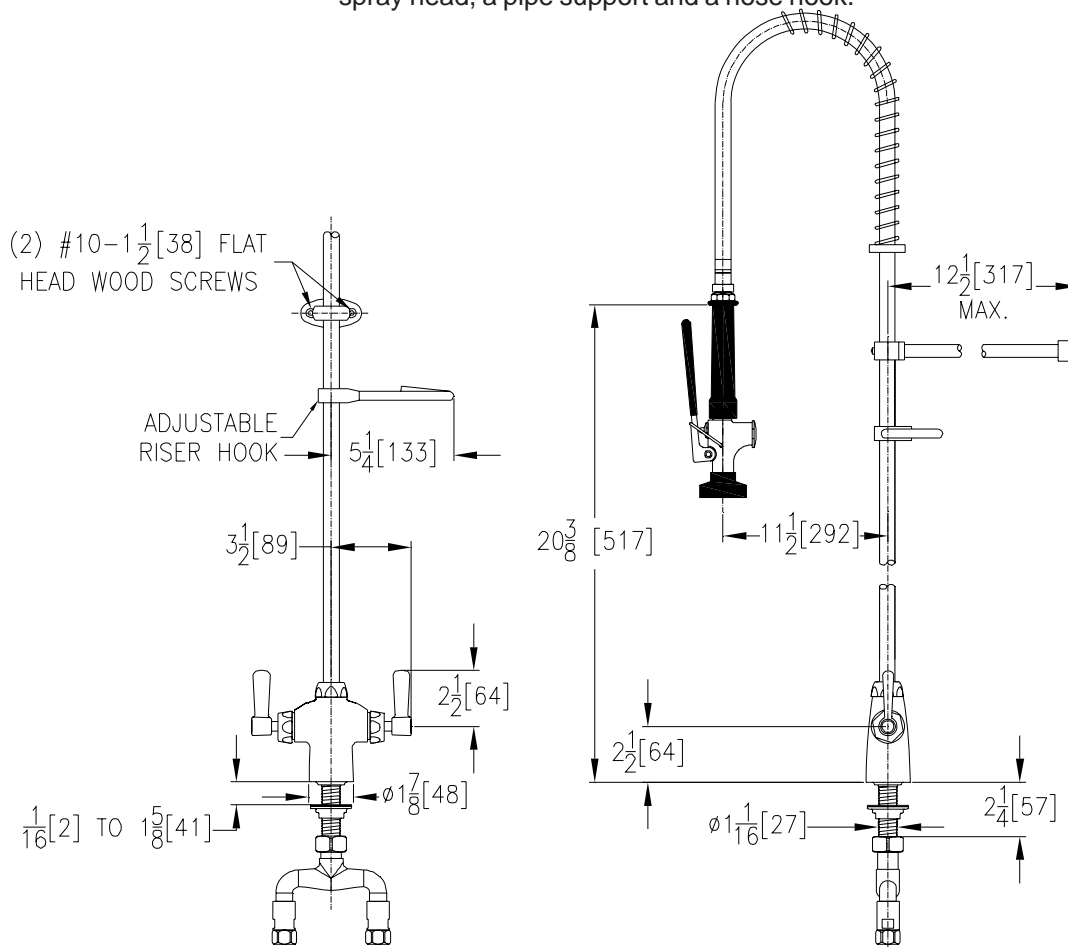

Note: All dimensions are for reference only. Do not use for pre-plumbing

OPTIONAL ACCESSORIES

Suffix	Description
___ -AR	Anti-Rotation Pins
___ -G	1-1/4"[32mm] Grid Strainer Drain
___ -HCT	Hot/Cold Text Indexes
___ -PR2	Pre-rinse with Angle Spray Head, Rubber Bumper Spray Outlet and Self-closing Valve
___ -PR3	Pre-rinse with Angled Aerated Outlet and Self-closing Valve
___ -PR6	Self-Closing Pre-Rinse Valve, Straight Nozzle with Diffuser
___ -PT	1-1/4"[32mm] Cast Brass P-Trap with a 7-1/2"[191mm] Long 17-Gauge Wall Bend

ZURN INDUSTRIES, LLC ♦ COMMERCIAL BRASS OPERATION ♦ 2640 SOUTH WORK STREET ♦ FALCONER NY 14733

Phone: 1-716-665-1132 ♦ Fax: 1-716-665-1135 ♦ World Wide Web: www.zurn.com

In Canada: ZURN INDUSTRIES LIMITED ♦ 3544 Nashua Drive ♦ Mississauga, Ontario L4V1L2 ♦ Phone: 905/405-8272 Fax: 905/405-1292