

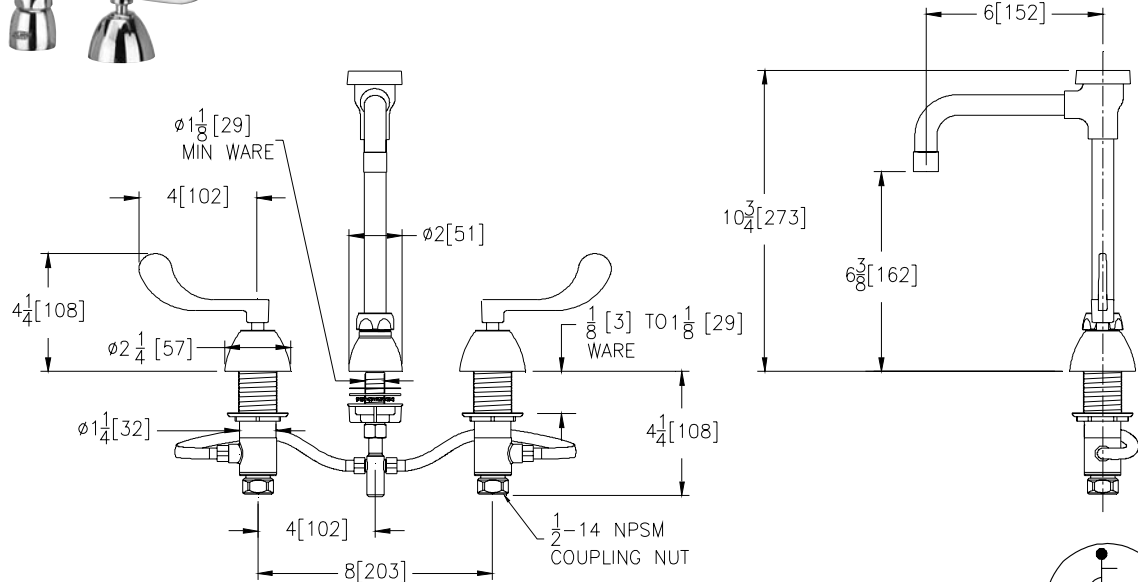

### Engineering Specifications: Zurn AquaSpec® Z831U4

Polished chrome-plated wide-spread with adjustable centers form 6" [152mm] to 20" [508mm], a 6" [152mm] centerline rigid gooseneck spout with vacuum breaker and quarter turn ceramic disc cartridges. Unit is furnished with a 2.2 GPM [8.3 L] pressure compensating aerator (complying with ANSI A112.18.1 Standard for flow), 4" [102mm] vandal-resistant color-coded metal wrist blade handles, mounting hardware and 1/2" NPSM coupling nuts for standard lavatory risers. Wide-spread accommodates installations up to 1-1/8" [38mm] thick.



Note: All dimensions are for reference only. Do not use for pre-plumbing



### OPTIONAL ACCESSORIES

Suffix	Description
___ -CWO	Cold Water Only
___ -FC	2.0 GPM [7.6 L] Laminar Flow Control in Base of Spout
___ -G	1-1/4" [32mm] Grid Strainer Drain
___ -HCT	Hot/Cold Text Indexes
___ -HS	Hose and Spray
___ -ICT	Inter-connecting Copper Supply Tubes for 8" [203mm] In-line Centers
___ -LP	Low Profile
___ -P	1-1/4" [32mm] Pop-up Drain
___ -PT	1-1/4" [32mm] Cast Brass P-Trap with a 7-1/2" [191mm] Long 17-Gauge Wall Bend
___ -TW	Third Waterway
___ -6M	2.0 GPM [7.6L] Male Serrated Nozzle
___ -7M	1.0 GPM [3.8 L] Pressure Compensating Male Spray Outlet
___ -16M	1.0 GPM [3.8 L] Vandal Resistant Pressure Compensating Male Spray Outlet
___ -17M	1.5 GPM [5.7 L] Vandal Resistant Pressure Compensating Male Aerator
___ -18M	1.5 GPM [5.7 L] Vandal Resistant Pressure Compensating Male Laminar Flow
___ -19M	1.5 GPM [5.7 L] Anti-Microbial Pressure Compensating Male Laminar Flow Outlet
___ -20M	1.0 GPM [3.8L] Vandal-Resistant Pressure Compensating Anti-Microbial Male Laminar Flow Outlet
___ -21M	1.0 GPM [3.8L] Male Laminar Flow Outlet
___ -22M	1.0 GPM [3.8L] Vandal-Resistant Male Laminar Flow Outlet

ZURN INDUSTRIES, LLC ♦ COMMERCIAL BRASS OPERATION ♦ 2640 SOUTH WORK STREET ♦ FALCONER NY 14733

Phone: 1-716-665-1132 ♦ Fax: 1-716-665-1135 ♦ World Wide Web: [www.zurn.com](http://www.zurn.com)

In Canada: ZURN INDUSTRIES LIMITED ♦ 3544 Nashua Drive ♦ Mississauga, Ontario L4V1L2 ♦ Phone: 905/405-8272 Fax: 905/405-1292

Rev. E

Date: 7/21/08

C.N. No. 107627