



Z1365

GROUND HYDRANT

Encased, Flush Type, Non-Freeze

SPECIFICATION SHEET

TAG _____

Dimensional Data (inches and [mm]) are Subject to Manufacturing Tolerances and Change Without Notice

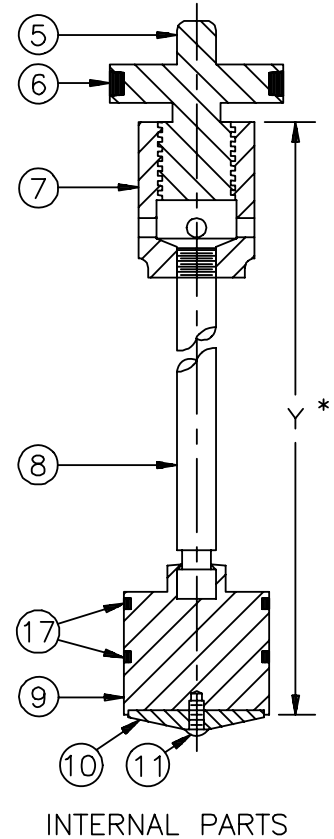
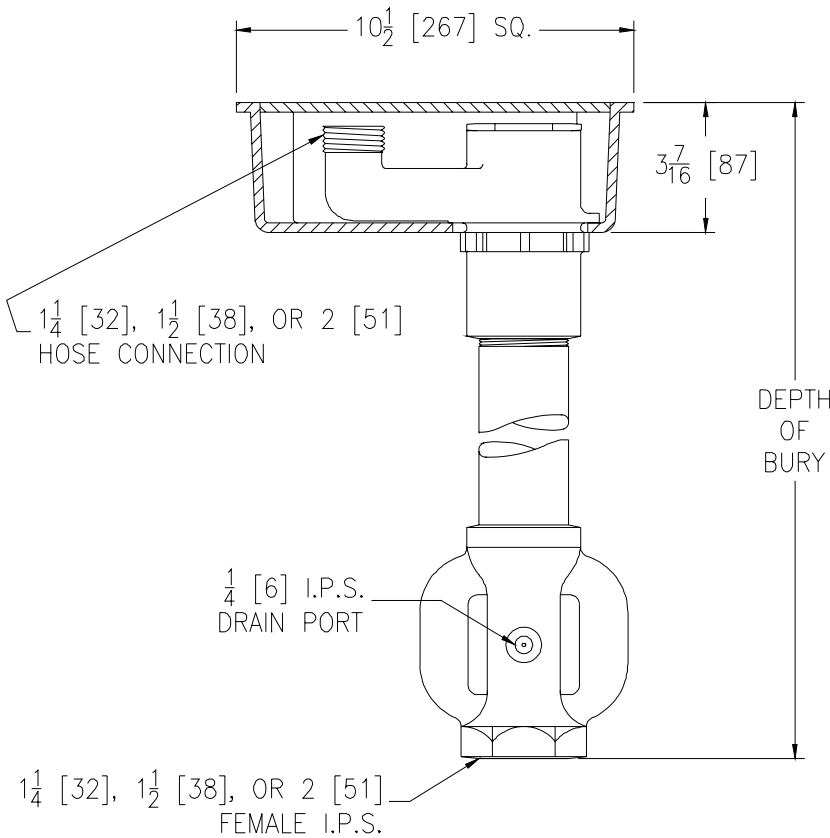

| Depth of Bury Feet | Approx. Wt. Lbs.[kg] |
|--------------------|----------------------|
| 2 [610] | 42 [19] |
| 3 [914] | 46 [21] |
| 4 [1219] | 50 [23] |
| 5 [1524] | 54 [25] |
| 6 [1829] | 58 [26] |
| 7 [2134] | 62 [28] |
| 8 [2438] | 66 [30] |

ENGINEERING SPECIFICATION: ZURN Z1365

Encased, non-freeze ground hydrant, for flush with grade or finished floor installation. Complete with galvanized steel casing, all bronze interior parts, bronze seat and replaceable seat washer, and non-turning operating rod with free-floating compression closure valve with 1 1/4 [32], 1 1/2 [38] or 2 [51] connection. Dura-Coated cast iron box and hinged scoriated cover with operating "T" handle key lock and "WATER" cast on cover. Hydrant is equipped with a tapped 1/4 [6] drain port in valve housing.

Note:

- IMPORTANT** Hydrant must be opened one turn to seal drain port during use.

CONNECTION TYPE:

- _____ 1-1/4 [32] Hose Connection
- _____ 1-1/2 [38] Hose Connection
- _____ 2 [51] Hose Connection

OPTIONS (Check/specify appropriate options)

SUFFIXES

- _____ -BC Bronze Casing
- _____ -DP14 1/4 [6] IP Drain Port in Box
- _____ -NB Polished Nickel Bronze Face
- _____ -PB Polished Bronze Face
- _____ -RB Plain Bronze Face
- _____ -RK Hydrant Parts Repair Kit

PARTS LIST

| Item | Name | Quan. |
|------|--------------------|-------|
| 5 | Operating Screw | 1 |
| 6 | O-Ring | 1 |
| 7 | Operating Coupling | 1 |
| 8 | Operating Rod | 1 |
| 9 | Washer Guide | 1 |
| 10 | Washer (neoprene) | 1 |
| 11 | Screw | 1 |
| 17 | O-Ring | 2 |

REV. F DATE: 1/29/09 C.N. NO. 99631

DWG. NO. 58879 PRODUCT NO. Z1365

*WHEN ORDERING REPLACEMENT PARTS SPECIFY Y DIM.

ZURN INDUSTRIES, LLC. ♦ SPECIFICATION DRAINAGE OPERATION ♦ 1801 Pittsburgh Ave. ♦ Erie, PA 16514

Phone: 814/455-0921 ♦ Fax: 814/454-7929 ♦ World Wide Web: www.zurn.com

In Canada: ZURN INDUSTRIES LIMITED ♦ 3544 Nashua Drive ♦ Mississauga, Ontario L4V1L2 ♦ Phone: 905/405-8272 Fax: 905/405-1292